

插头建议开孔尺寸
Recommended hole size for plugs

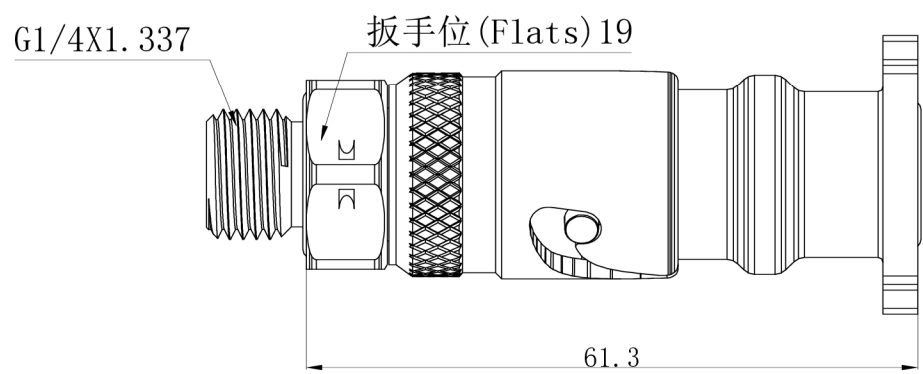

BST-BT-5PALFVR2G14

BST-BT-5SALFVR41818

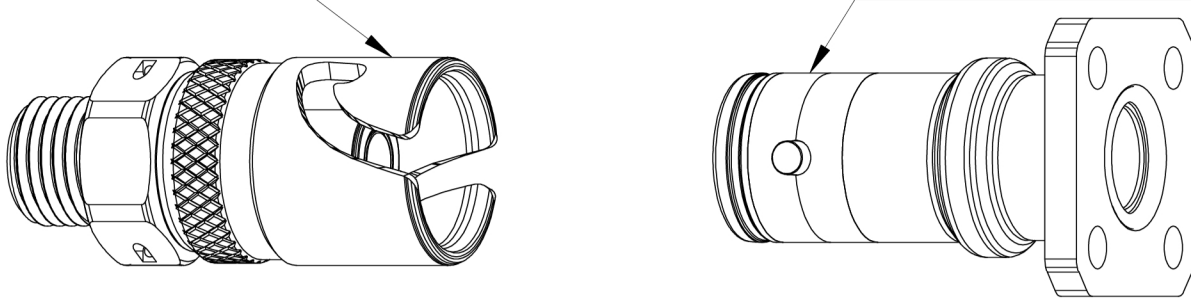

版本号 Version No.	内容 Content	设计 Designer	日期 Date
△1			
△2			
△3			
△4			
最大工作压力 Maximum Working Pressure			20 Bar
工作温度 working Temp			-50~175 °C
最大工作流量 Maximum Working Flow			6.88 L/min
机械寿命(插拔次数) Mechanical Life(Plugging Time)			>1000 次 time
密封方式 Sealing Mode			双向 double
名称 Name			参数 Parameter
主体材质 (可选) Material of Main Body (selecaable)		6061-T6	
O型圈材质 Material of O-ring		FVMQ	
介质 Medium		冷却液、水-乙二醇 coolant, water-ethylene glycol	
名称 Name			参数 Parameter

注意事项:
1. 禁止超过最大工作压力、温度、流量使用;
2. 禁止将产品作为铰链接头使用;
3. 禁止将产品与本公司以外的产品互换使用;
4. 禁止私自拆卸产品或拆卸后更换零部件后再使用;
5. 禁止应用在可用介质以外的流体中;
6. 安装使用需考虑防松措施;
7. 工作介质须保证流体洁净度, 推荐优于GJB420B-9级;
8. 使用前, 确保流体连接器洁净无污染;
9. 安装或使用过程中有漏液或其他任何问题, 请联系我司。
Matters needing attention
1. Do not use over the maximum working pressure and the maximum temperature and the maximum flow;
2. Do not use the product as a hinge joint;
3. It is forbidden to use the product interchangeably with other products outside the company;
4. It is forbidden to disassemble the product without permission or replace the parts after disassembly before use;
5. Do not use in fluids other than available media;
6. Loose-proof measures shall be considered for installation and use;
7. The working medium shall ensure the fluid cleanliness, which is recommended to be better than GJB420B-9;
8. Ensure that the fluid connector is clean and pollution-free before use;
9. Please contact us for any leakage or other problems during installation or use.

备注 Note	
颜色 (色号) Color (Color Number)	



X	±0.5	产品型号 Item NO.	BST-BT-05	产品名称 Item Name	流体连接器 Fluid Connector	材料 Material		产品物料号 Product Material No.	倍仕得货号 Beisit No.
X.X	±0.3	制图 Drawer	毛天良/Tianliang Mao	日期 Date	2023/7/26	单位 Unit	MM	/	BST-BT-5PALFVR2G14 BST-BT-5SALFVR41818
X.XX	±0.08	设计 Designer	毛天良/Tianliang Mao	日期 Date	2023/7/26	比例 Scale			
X.XXX	±0.05	审核 Approved by	李小强/Roy Li	日期 Date	2023/7/26		视图 View		

A B C D E F